

1 2 3 4 5 6 7 8

A

B

C

D

E

F

G

H

A

B

C

D

E

F

G

H

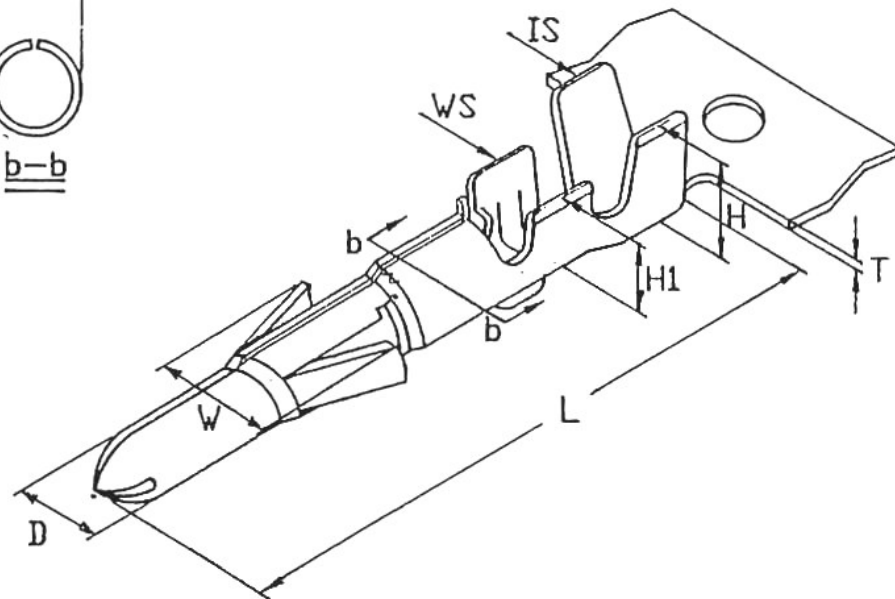

DIMENSION: (MM)

T: 0.2 ± 0.03

L: 16.8 ± 0.3

IS: 3.7 ± 0.35

WS: 2.1 ± 0.35

H: 3.5 ± 0.3

H1: 2.2 ± 0.3

D: 1.58 ± 0.03

D1: $2.1^{+0.1}_{-0.05}$

W: $3.0^{+0.25}_{-0.1}$

MATERIAL: BRASS

THICKNESS: 0.2

HARDNESS: SH

PLATING: TIN 40 u" MIN.

WIRE RANGE: (AWG) 18-24

INSULATION O.D.: 2.5 MAX

RATED VOLTAGE: AC, DC 250V

CURRENT RATED: AC, DC 5A

TEMPERATURE RANGE: -25°C TO +105°C

玄茂科技股份有限公司
HSUAN MAO TECHNOLOGY CO., LTD.

UNIT

MM

SCALE

1:1

PART NAME

3.68mm ϕ 1.58mm TERMINAL
MALE

APPD.

CKD.

TOLERANCE

± 0.5

PART NO.

T1058-TBG00000

REV.

A

制表日: 2002/10/12

DRAWING.

Jane

APPROVED

1

2

3

4

5

6

7

8